

Plus

Portable interior billboard

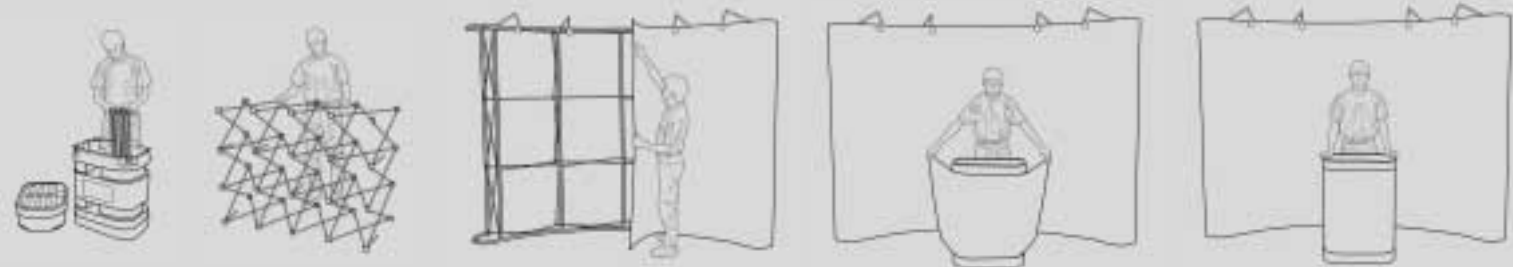

Niva Plus, representative of Pop-up system, provides effective and intellectual presentation during the marketing activities. It represents compact, light-weight and portable structure unfoldable in a moment. By adding of magnetic bars to the structure you receive a wall where you can very easily to apply a magnetic panels. Different sizes and graphic motives bring many options how to make your presentation unforgettable. Only one person can fold and unfold Pop-up system in a few minutes and use the transportation case as an elegant presentation table during your presentation. System Niva Plus is standardly delivered in blue nylon bag and blue tube, optionally in black transport case which is also suitable for air transportation. Front and back show-cases are elegant and practical accessories for Niva Plus. Available in two different highs: Plus 208 cm and MaxiPlus 230 cm.

MaxiPlus

Type of the product/ Technical data	MaxiPlus 3x4	MaxiPlus 3x3	MaxiPlus 3x2	MaxiPlus 3x1
Weight* (kg)	31,5	24,6	21,9	17,6
Cover dimensions (cm) WxHxT	80x30x30	80x30x30	80x30x30	80x30x30
HxD	76x39	76x36	76x30	76x30
Visible ad. area (cm) HxW	curved	231,5x408	231,5x337,6	231,5x267,2
	flat	231,5x430,4	231,5x354,4	231,5x278,4
Material	Structure-duralumin, magnetic bars-aluminium with eloxal coating, PVC 0,4mm			
Cover	blue nylon bag, blue plastic case			

*- weight consists of structure, PVC panels, magn. bars, magn. tapes, bag, tube

Plus

Type of the product/ Technical data	Plus 3x4	Plus 3x3	Plus 3x2	Plus 3x1
Weight* (kg)	25,4	21,7	17,9	14,1
Cover dimensions (cm) WxHxT	80x30x30	80x30x30	80x30x30	80x30x30
HxD	76x39	76x36	76x30	76x30
Visible ad. area (cm) HxW	curved	208,5x379,2	208,5x316	208,5x252,8
	flat	208,5x399,6	208,5x331,3	208,5x263
Material	Structure-duralumin, magnetic bars-aluminium with eloxal coating, PVC 0,4mm			
Cover	blue nylon bag, blue plastic case			

*- weight consists of structure, PVC panels, magn. tapes, magn. bars, bags, tube

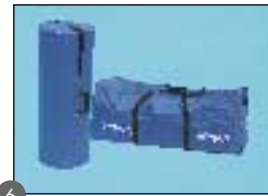

- 1 Detailed gripping of bars Plus
- 2 Front show - case
- 3 Side show - case
- 4 Halogen lamp 50 W
- 5 Prestige lamp 200 W
- 6 Bags for construction, bars and panels



Using the plastic case:

- 1 Protection of the structure, panels, magnetic bars and halogen lamps
- 4 Effective helper during the pannels instalation
- 5 Plastic case used like presentation table

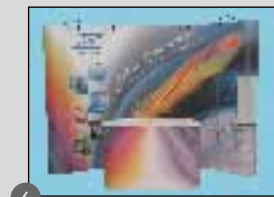

Maxi Plus

- 1 Maxi Plus flat structure 3x1
- 2 Maxi Plus flat structure 3x2
- 3 Maxi Plus flat structure 3x3
- 4 Maxi Plus flat structure 3x4

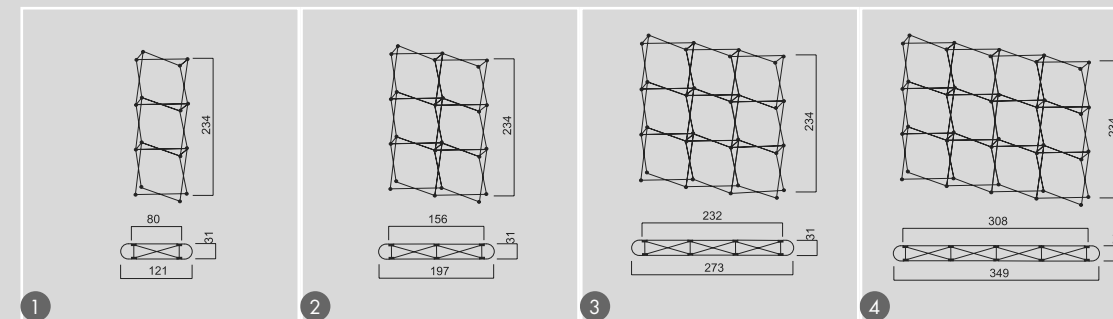

- 5 Maxi Plus curved structure 3x1
- 6 Maxi Plus curved structure 3x2
- 7 Maxi Plus curved structure 3x3
- 8 Maxi Plus curved structure 3x4

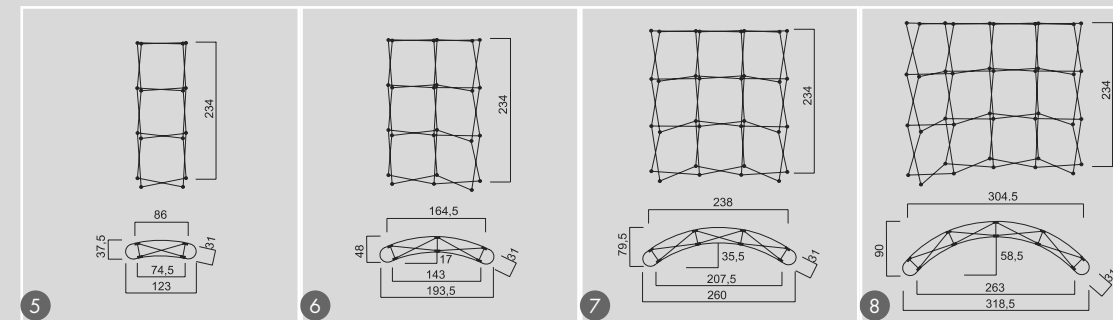

Plus

- 1 Plus flat structure 3x1
- 2 Plus flat structure 3x2
- 3 Plus flat structure 3x3
- 4 Plus flat structure 3x4

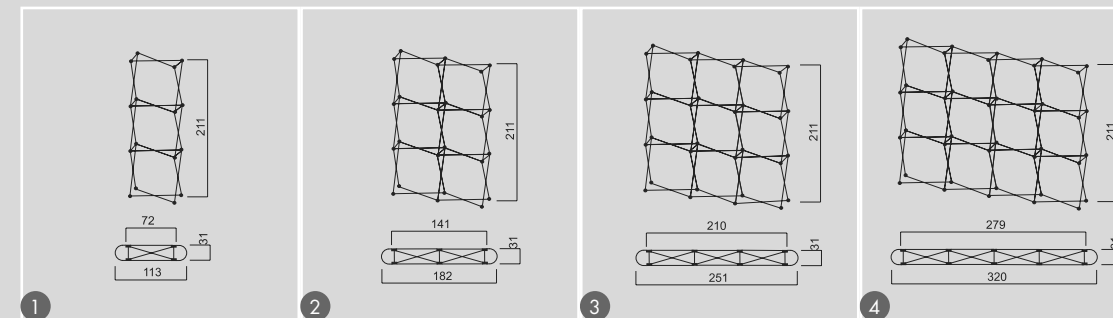

- 5 Plus curved structure 3x1
- 6 Plus curved structure 3x2
- 7 Plus curved structure 3x3
- 8 Plus curved structure 3x4

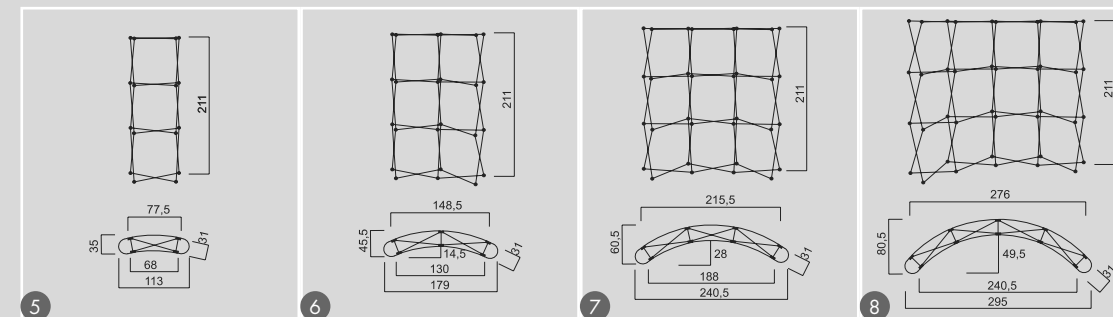

*PARAMETERS MENTIONED IN THIS PART ARE DIMENSIONS OF THE STRUCTURES, NOT GRAPHIC PANELS