

Tex Compact

Effective fabric display wall



Niva TexCompact is probably the fastest way how to create effective presentation on the textile. For less than one minute you can built up a presentation wall Tex Compact with graphic area bigger than 5 m². Great advantage of Tex Compact system is the fact that graphic motive is portable in the transport bag directly in the structure. Textile graphic part is immediately strained after unfolding the structure and you receive smooth surface for your presentation. TexCompact is portable in nylon bag.

TexCompact

Type of the product/ Technical data	TexCompact 3x4	TexCompact 3x3	TexCompact 3x2	TexCompact 3x1
Weight* (kg)	6,20	5,10	4,10	3,20
Cover dimension (cm) WxHxT	80x30x30	80x30x30	80x30x30	80x30x30
Visible ad.area (cm) HxW	207,5x275,5	207,5x207,5	207,5x139,5	207,5x72
Material	Structure-duralmin, dry zipper			
Cover	Blue nylon bag			

*- weigh consists of structure, without graphic, with bag, dry zipper



- 1 Detailed gripping of fabric display by velcro
- 2 After folding the wall fabric panel is still caught on the structure
- 3 Back - view
- 4 Nylon bag for the structure and fabric display
- 5 Prestige lamp 200 W





Tex Compact

Effective fabric display wall

Tex Compact

- 1 TexCompact 3x1
- 2 TexCompact 3x2
- 3 TexCompact 3x3
- 4 TexCompact 3x4

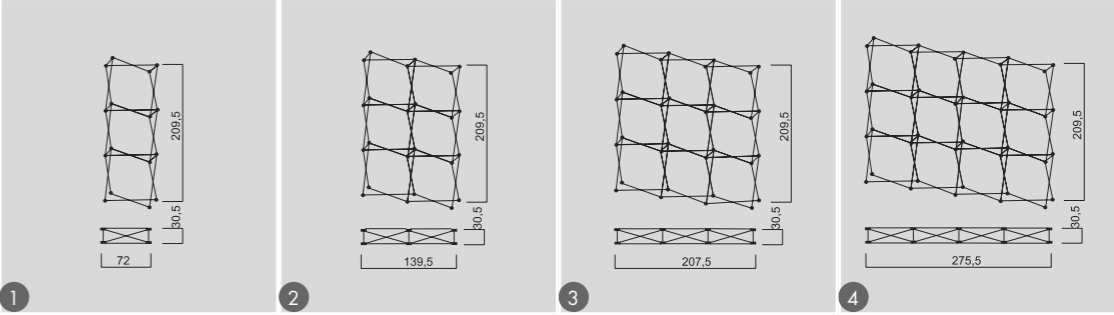

Tex Compact

- a TexCompact 3x4
- b TexCompact 3x3
- c TexCompact 3x2
- d TexCompact 3x1

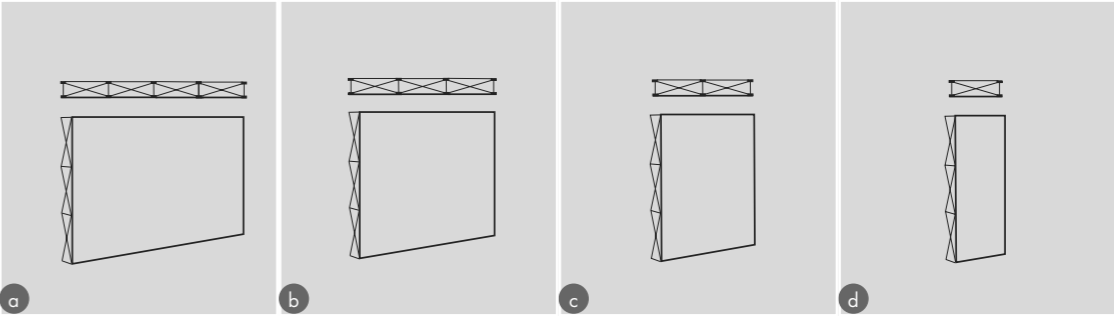

- e TexCompact Extra 3x4
- f TexCompact Extra 3x3

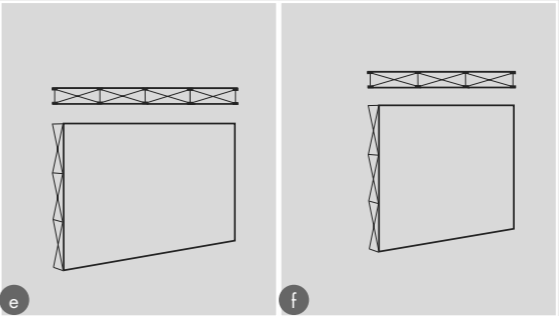

*PARAMETERS MENTIONED IN THIS PART ARE DIMENSIONS OF THE STRUCTURES, NOT GRAPHIC PANELS